

Tufting

Products and services
for the tufting industry



Contents

Groz-Beckert	4
Product range	5
Technology	6
Products	8
Tufting system	10
Needles and needle modules	12
Loopers and looper modules	13
Reed finger module	14
Tufting knives and knife modules	15
Services	16
Regrinding service	18
Application consulting	19
Online Catalog Tufting	20
Groz-Beckert Academy	21
App myGrozBeckert	22

Tradition and Future

Groz-Beckert was founded in 1852 and is active in over 150 countries today with around 7,700 employees. Whether for knitting, weaving, felt-ing, tufting, carding or sewing: Our total product portfolio contains over 70,000 products. As a leading supplier of industrial machine needles, precision parts, precision tools, systems and services for a wide range of textile production and joining methods, Groz-Beckert supports its customers and partners within the textile value chain – and beyond: The Technology and Development Center (TEZ) is a pioneering platform with which Groz-Beckert has been shaping the future of the textile industry together with machine manufacturers, end users, textile producers and institutes since July 2010.

Groz-Beckert

Textiles are everywhere and are found in a wide variety of shapes and functions in all areas of life: Fashion, sports and leisure, home textiles, flooring or in architecture. And textiles are also indispensable for mobility – from cars to space travel – and

for health. Groz-Beckert manufactures machine needles, precision parts and precision tools and offers supporting services for all aspects of the textile industry, from fashion, home and domestic textiles to technical textiles.



Technology and Development Center

Groz-Beckert represents reliable product quality and customer service in the world of textiles. The Technology and Development Center (TEZ) was opened in 2010 in order to develop new development and application fields for textiles in cooperation with customers and partners. Not only is the TEZ furnished with state-of-the-art equipment, it also provides the perfect environment for bundling the competencies and knowledge of Groz-Beckert. As a future-oriented company, Groz-Beckert places great value on the research and continued development of new technologies and application fields in the textile industry.

About Groz-Beckert

- Founded: 1852
- Head office: Albstadt, Germany
- Employees: 7,628 (as of 31.12.2014)
- Sales: 571 million euros (2014)
- Production companies:
Germany, Czech Republic,
Portugal, USA, India, China,
Vietnam, Belgium
- Distribution network:
Distribution subsidiaries and part-
ners in over 150 countries

Tufting product range

Until 1980, Groz-Beckert was active exclusively in the field of knitting and warp-knitting machine needles. Then the product range was expanded to include sewing and shoe machine, felting and structuring needles. Tufting needles and knives, loopers and reed fingers were added to complete the product range in the years 1998 through 2004 by acquiring the brands Eisbär, SNF and Schlemper.

Tufting – a definition

Tufting describes a method based on the sewing machine principle, used to manufacture carpets, high quality interior and trunk carpeting in vehicles and artificial turf for sports facilities and landscaping. Machine tufting methods use needles to insert the so-called pile yarn into a carrier material. The yarn is fed individually to each of the needles in the needle row, which is the same width as the final product. Then the tufting needles are inserted into the primary backing cloth, a woven or non-woven material. Loopers pick up the yarn before the needles are retracted again. Repeating this process creates a loop pile. Depending on the machine type, the loops can be cut open to create a cut pile. It is also possible to combine loop and cut pile through highly advanced machine, patterning and software components. The carpet types are generally divided into cut pile, loop pile, cut loop and level cut loop.



The tufting technology

Whether as a carpet, flooring, bath mat or artificial turf – tufted surface textiles are found everywhere, including as high-quality fabric trim in vehicles. Groz-Beckert has the right gauge parts for all processing techniques in its program, from individual modules to perfectly integrated complete systems.

For all manufacturing methods

Tufting utilises a backing material (non-woven or woven). The pile yarn is attached into this backing material. The different designs are primarily created with the following four techniques:

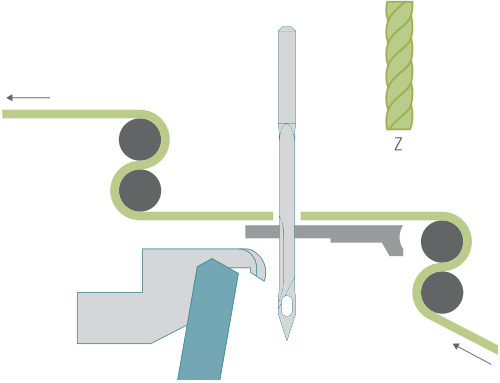

For cut pile, the yarn loops are cut by a special cutting system in an additional step. This cutting process uses a scissor action of the looper and tufting knife.

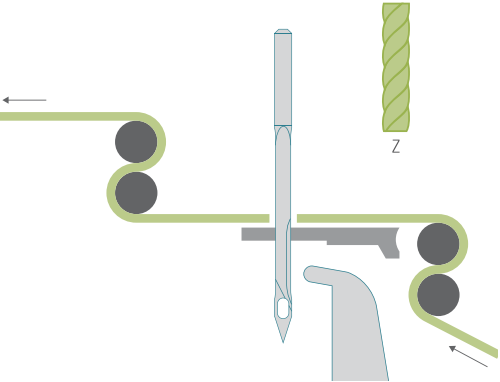

For loop pile, the carpet surface is formed out of individual yarn loops.

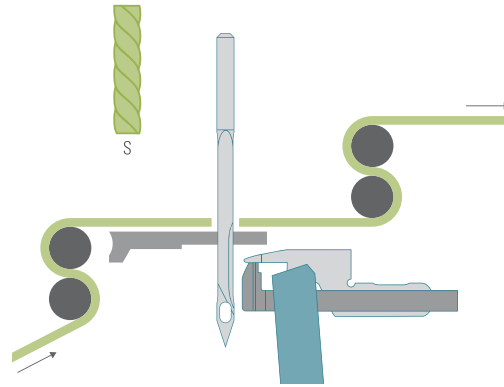

In the combination of loop and cut pile (cut loop), the high cut pile loop is produced at normal yarn tension and the low loop pile loop is produced at a low yarn tension.

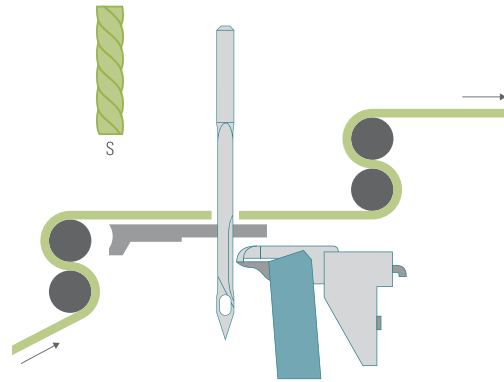
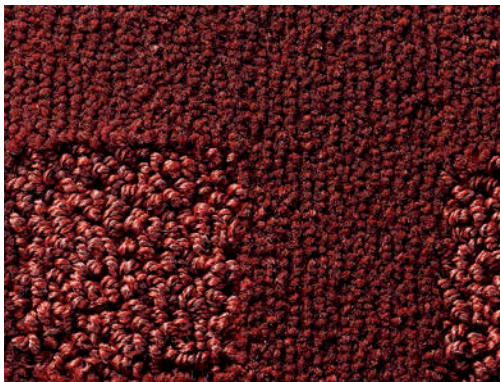

A special combination of loop and cut pile (level cut loop) is produced with air-controlled loopers. If additional patterns are used, different yarn tensions lead to the desired results.



Products

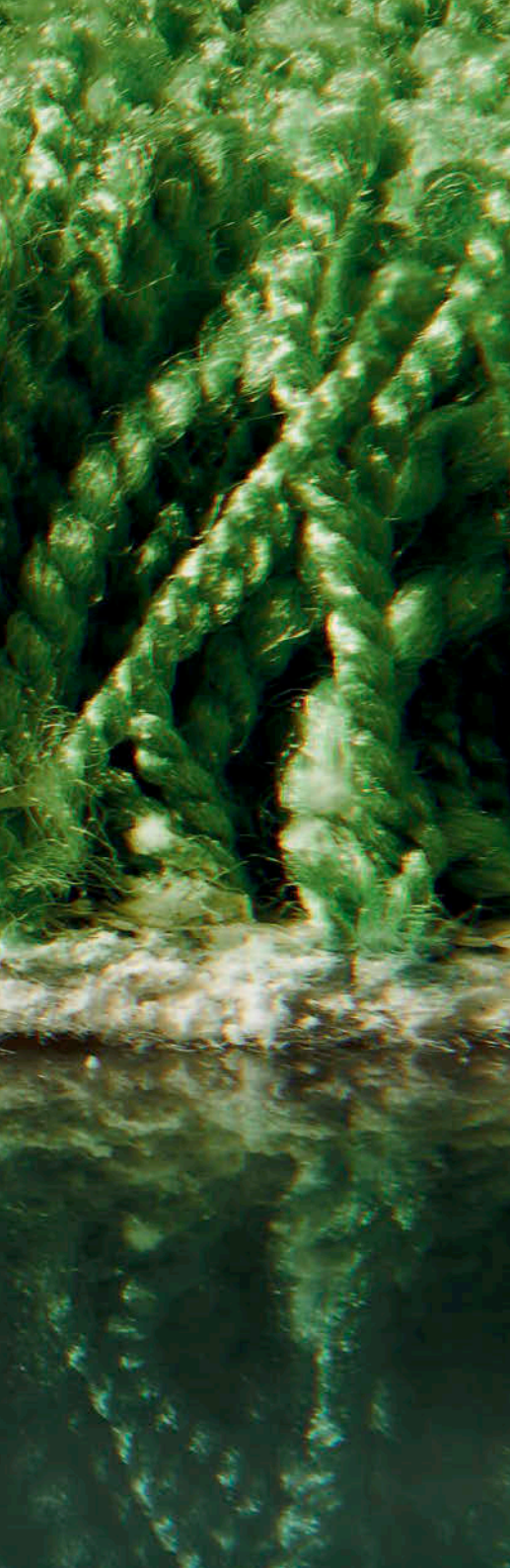

The full program

Tufting gauge parts by Groz-Beckert do all the work: They create the basis for tufted surface textiles. As a carpet or bath mat, artificial turf for sports facilities and landscaping or for high quality fabric trim in vehicles. Tufting machines with a width of up to five metres and up to 4,000 needles, loopers, reed fingers and knives produce high quality textile surfaces at speeds of up to 1,500 RPM. This is only possible in the first place thanks to the perfect coordination and performance of the tufting gauge parts!



Application-specific tufting systems, precise, high-performance and durable tufting needles and needle modules, loopers, looper modules, reed finger and tufting knives: Groz-Beckert offers a full range of tufting gauge parts, which are introduced below.

The tufting system

The use of Groz-Beckert tufting gauge part systems produces measurable benefits in the manufacturing of tufted flooring. The Groz-Beckert tufting system as a whole stands for the highest precision and process reliability – with all components from a single source.



Perfect combination, optimal interaction

The perfectly matched combination of materials and the functional interaction of all tooling components ensures that the tufting process produces high quality and economical results. The Groz-Beckert systems approach for the use of tufting gauge part systems in all relevant tufting applications pays off. It is developed systematically to satisfy the

constantly increasing requirements of industry with regard to precision and process reliability.

The Groz-Beckert gauge parts are developed in close cooperation with, and under consideration of, the requirements and experience of the tufting machine manufacturers, raw material suppliers and in partnership with our customers around the world.

Highest standards

The company places especially high importance on the optimal selection, use and combination of particularly high quality materials – in an advanced production process with strict quality standards. This is ensured through state-of-the-art laboratory and analysis methods.





Process reliability through the Groz-Beckert gauge part system

- Development competency
- Process competency
- Production competency
- Application competency



Needles and needle modules

Groz-Beckert combines tradition and innovation for state-of-the-art needle technology. The company is renowned around the world for high quality tufting needles in all tufting applications.

Individual needles and needle modules for all needs applications

Tufting machine manufacturers and carpet manufacturers value the constant high quality and reliability of the products. They also recognize Groz-Beckert as a competent and reliable development partner for all customer-specific requirements. With good reason: Because they receive a full range of needles for all applications and all machine generations. Groz-Beckert needle modules are characterized by

consistently high quality, precision accuracy and long service life, all the way down to the finest of gauges. The product range includes all conventional module types and fixing systems. The use of the needle modules minimizes set up times. As a systems supplier, Groz-Beckert guarantees optimal coordination of the tufting system.



Loopers and looper modules

Problem-free and efficient production is guaranteed through the consistent quality and precision of the individual loopers and looper modules.

The innovative looper geometry for loop pile goods and velour

The reliable operation of loop pile and cut pile loopers is the basis for a flawless and high-quality product appearance, both with single loopers and in modular designs.

The geometries of Groz-Beckert loopers are optimally adapted to the respective applications. This is why the consistent and precise quality of single loopers and looper modules is a matter of course.

As a component of Groz-Beckert tufting systems, the design and material selection of single loopers and looper modules is matched perfectly so that they interact smoothly. Differing requirements demand individual combinations of the different tufting tools. Many different carpet types have to be supplied with the perfectly matched tools.

Always a perfect fit – single loopers and looper modules

The tufting industry makes use of different take-up systems – for individual part configuration as well as for module design. As a full assortment provider, Groz-Beckert offers the right tufting tools and tufting systems for every variation. In partnerships and joint ventures with leading tufting machine manufacturers, the tufting tools are continuously refined for the very latest machine generations.

Just like Groz-Beckert tufting needles, Groz-Beckert loopers and looper modules are also impressive with their consistently high precision and service life, right down to the finest gauges. The product range includes all conventional module types and fixing systems. Using modules from Groz-Beckert reduces set up times noticeably in any case.

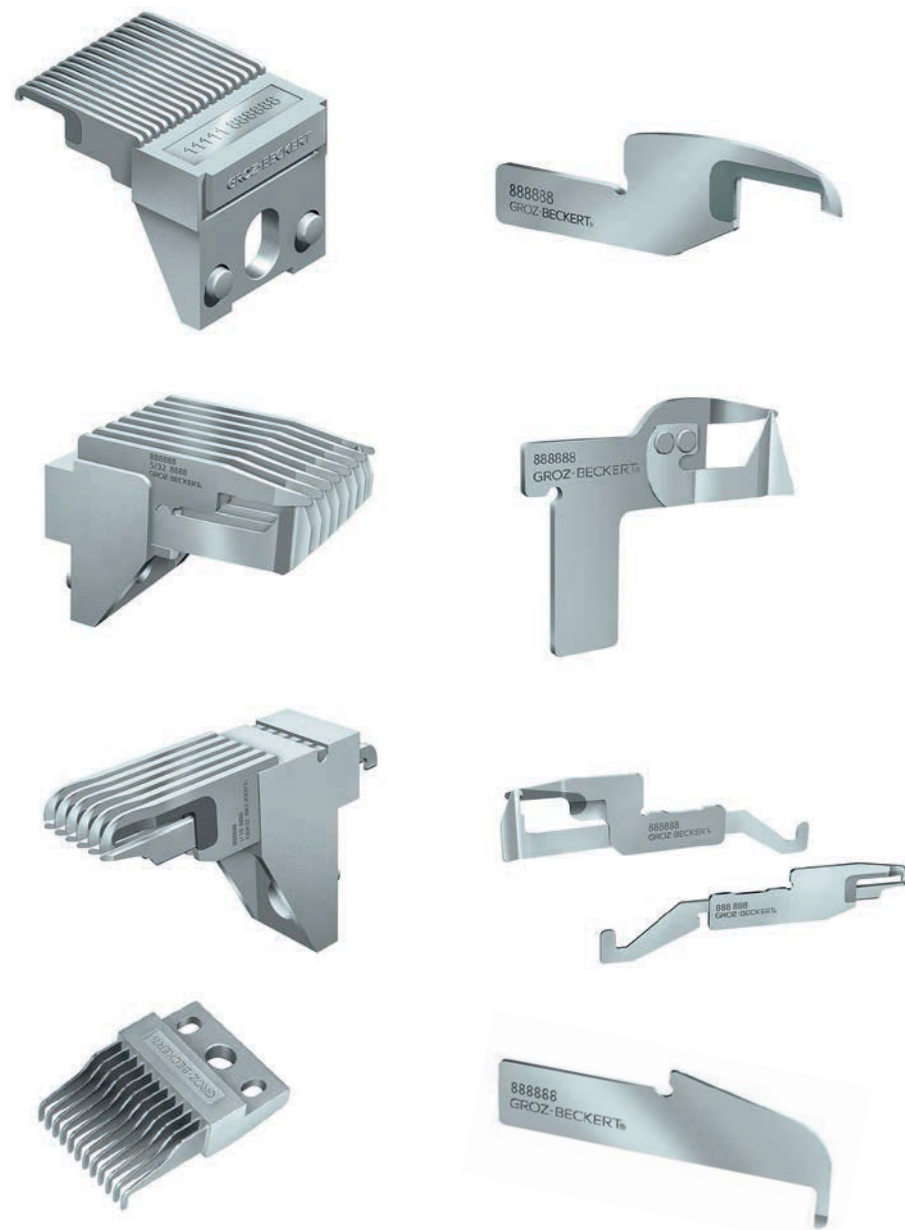

Reed finger module

Straight, offset or in combination: Groz-Beckert offers a wide range of reed finger modules.

Flawless product appearance, reduced cost

A system provider thinks of everything: Thus the Groz-Beckert tufting product range also includes a complete assortment of reed finger modules for all gauges. The precision of the Groz-Beckert reed finger modules ensures a uniform and flawless product appearance – and minimizes set up requirements. All reed finger modules are available with the familiar fixing systems.



Straight



Offset



Straight and offset combined

Tufting knives and knife modules

The selection and utilization of high-quality materials and special production processes has formed the basis of the outstanding quality of Groz-Beckert tufting knives for years.

Quality which sets standards around the world

Users worldwide can rely on the uniform quality regardless of the batch sizes. This has made Groz-Beckert tufting knives the benchmark for today's industry standard. They represent the highest quality materials, uniform high quality, precisely ground blades and matched high quality steels. All gauges are available for any conceivable application, as are all relevant cutting and opening angles.

Combining them with the Groz-Beckert cut pile loopers ensures a uniform cut appearance and thus an optimal product appearance, even when using sensitive yarn types. Groz-Beckert provides custom solutions such as tufting knife modules for special applications and gauges.



Tufting knives with carbide cutting inserts – particularly well suited for high-end applications such as automotive carpets



Standard tufting knives – universal all-rounder for all applications

Services





Always on the safe side

Regrinding service for tufting loopers and tufting knives for both individual parts and modules, competent application consulting – including online catalog, app and training at the Groz-Beckert Academy: Tufting Services have a lot to offer.

Regrinding service

Groz-Beckert offers a regrinding service for tufting loopers and tufting knives it manufactures, regardless of whether they are individual parts or modules.

High sharpness – for high process reliability

A regrinding service for tufting loopers and tufting knives for individual parts and modules increases the service life of gauge parts and makes them more cost effective. Regrinding meets the Groz-Beckert OEM quality you rely on, allowing the products to reach their maximum service life and to continue producing high quality and high value products.

The knives and loopers are inspected upon receipt. If the wear pattern isn't normal, we contact the customer to discuss possible misadjustment of the machine. Loopers and knives in modules can be ground in stages according to their degree of wear. After regrinding, they get a colour code. Identical items with identical colour codes can then be used together in one machine.

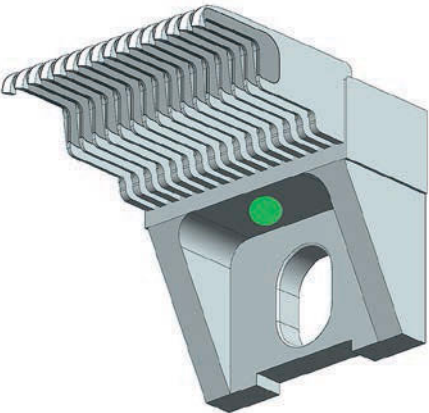

Colour / identifier	RAL Colour	Regrind
Green	6002	1. Regrind
Yellow	1016	2. Regrind
Orange	2004	3. Regrind
Red	3031	4. Regrind
Black	9005	5. Regrind

Sample colour table for regrinding of cut-pile looper modules

TI/SC
CPLM &
LCLM

HSS
CPLM &
LCLM



Application consulting

Groz-Beckert has many years of experience in the tufting industry and extensive expertise in application consulting.

Technical Tufting Center – worldwide, from consulting to solutions

Groz-Beckert offers a unique package of application consulting services. With the help of the Technical Tufting Center, specific solutions can be efficiently developed together with users.

Comprehensive expertise in all areas of the tufting industry is a given: From the production of automotive carpeting to wall-to-wall and artificial turf. Experienced experts develop solutions and support you in a wide range of areas. The support ranges from selecting the optimal tufting tools to basic testing, further development of tools and process optimization to quality assurance including material and fault analysis.



Online Catalog Tufting

With the Online Catalog Tufting, Groz-Beckert offers an innovative and constantly updated tool to easily find and identify tufting gauge parts.

The interactive system can be used free of charge after successful registration, and its intelligent and detailed solutions set new standards. Fast, up to date product requests, intuitive interface to help you find the right product, and high request quality – including conveying basic know-how: All of this is possible thanks to the interactive support.

You can access the Online Catalog Tufting at tufting.groz-beckert.com.

www.groz-beckert.com | Home | About us | Terms and conditions | Forgot password? | Login request | Login | deutsch

Loop pile tufting

GROZ-BECKERT®

Portrait tufting

Basics and training

- Product samples and application
- Tufting principles
 - Loop pile
 - Cut pile
 - Cut loop
 - Level cut loop
- Gauge parts
- Glossary
- Carpet faults and their correction

Product catalog

For loop pile tufting there has to be a needle, a reed dent (or needle plate), and a looper. These are known as loop pile gauge parts.

The loop pile process

To produce a loop pile tufted carpet, the needle pulls the yarn through the primary backing cloth. As the needle begins the up stroke the yarn is picked up by a looper or hook below the cloth. When the needle is removed from the cloth the looper forms the loop by holding back the yarn.

The action is repeated on every revolution of the machine. On each penetration of the needle the previous loop is released by the looper as it rocks back. The use of different pattern attachments can create patterns and texture by yarn tension control for any given needle.

play pause stop

Loop Pile L Loop Pile R

KNITTING , WEAVING , FELTING , TUFTING , SEWING

In addition to text explanations, the Online Catalog Tufting also has demonstration videos and drawings you can access.

Groz-Beckert Academy

Groz-Beckert supports its customers and partners with full service support within the textile value chain. This also includes developing knowledge as well as conveying and passing this knowledge on. The company offers a comprehensive training program through the Groz-Beckert Academy, covering the most important textile manufacturing and joining processes.

Share and pass on knowledge, impart experiences, make know-how and competencies accessible – these are the core competencies of the Groz-Beckert Academy. Experienced trainers teach specialist knowledge to Groz-Beckert colleagues and customer employees in application-oriented courses. The training is carried out according to the latest methodological and didactical findings.

In addition to numerous basic, advanced and special training courses which are held in the Technology and Development Center (TEZ) in Albstadt, custom training sessions on-site at the customer are available as well. Courses are offered in German, English, Spanish and Chinese. Further languages are available upon request.

Download the current training program:



App myGrozBeckert

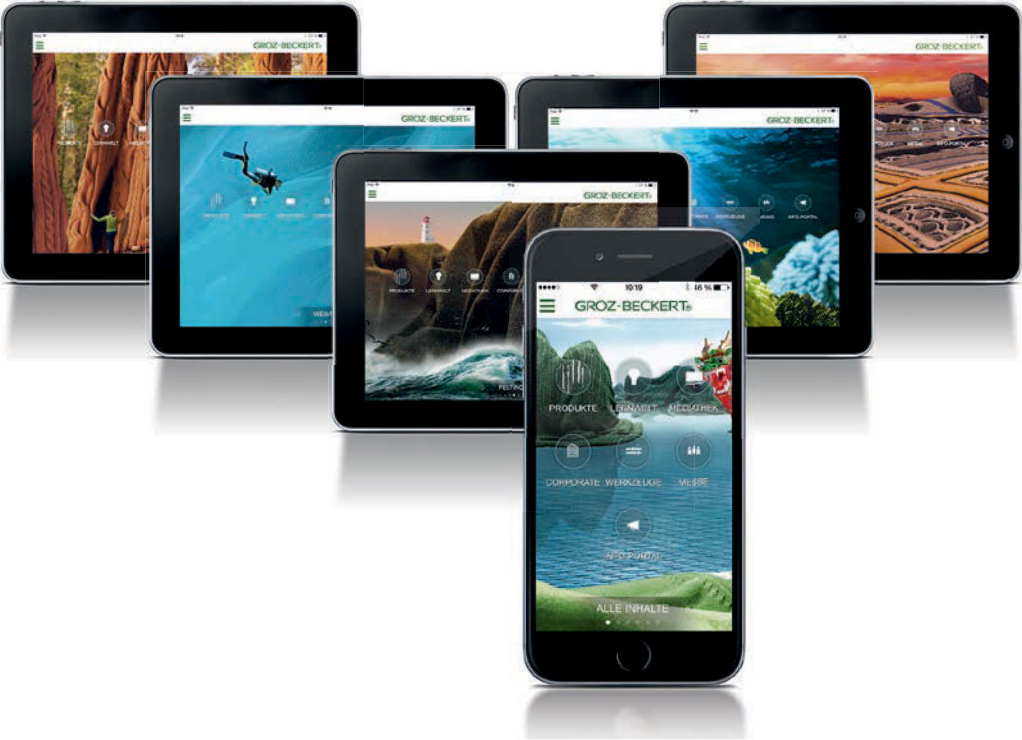

The world of textiles in a single App

Know more and work more efficiently – that's what "myGrozBeckert" is all about. The App contains well-founded knowledge of the textile value chain and Groz-Beckert, as well as numerous useful tools and calculation apps in the so-called "Toolbox". The App features a user-friendly navigation structure with intuitive user guidance in order to find the

required information as quickly as possible. The App settings can be customized as well. The free App is available for all smartphones and tablets with the iOS and Android operating systems, and in the languages German, English and Chinese.

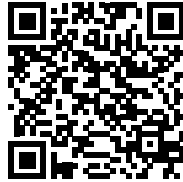

Groz-Beckert KG

Parkweg 2

72458 Albstadt, Germany

Phone +49 7431 10-0

Fax +49 7431 10-2777

contact-tufting@schmeing.com

www.groz-beckert.com



The depictions provided of our products are not to scale and are intended for illustrative purposes only. Consequently they make no claim to be an accurate representation of the original.

® = Registered trademark of the Groz-Beckert company group.

© = This publication is copyrighted.

All rights reserved, in particular the right of duplication, distribution and translation. This publication or any parts thereof may not be reproduced or stored, processed, duplicated or distributed using electronic systems in any form or by any means whatsoever without the express written consent of Groz-Beckert.

KNITTING , WEAVING , FELTING , TUFTING , CARDING , SEWING

